

CRANBORNE AUDIO

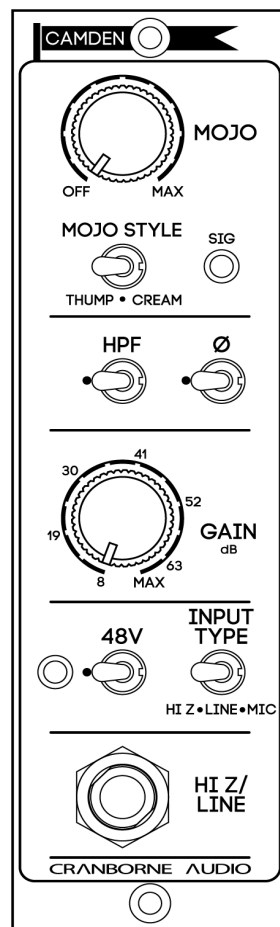

Camden 500 - 500 Series Preamp And Signal Processor User Manual

Welcome to our family

Cranborne Audio represents a commitment by four product designers to build an audio brand that does things the right way. We don't take shortcuts. We don't compromise. We don't accept "good enough."

We're just like you. We're musicians. We're audio engineers.

We make products that we want to use. We create, innovate, and design with passion, purpose, and belief. We strive to design products that remain accessible whilst offering the highest quality and truly innovative new ways of working and achieving that sound that we all desire.

Cranborne Audio, for us, means so much more than metal boxes with components in them. These are our labours of love that embody and demonstrate our demand for excellence. By distilling what matters and putting our soul into these tools, we hope to help other people make magic and express themselves, and in some way, become part of our Cranborne Audio family.

So welcome to our family. We care for our family. And we care about making your tracks, albums, scores sound as good as they should.



Sean Karpowicz



Edward Holmes



Elliott Thomas



Andrew Pat

Cranborne Audio Camden 500

Congratulations on your purchase of the Camden 500 Preamp and Signal Processor and thank you for selecting Cranborne Audio to be a part of your music creation process.

There are a lot of mic preamps out there. A lot of them add colour and the most loved and desired transformer-based circuits add a lot of colour. On some sources it's for the better, on others it's most certainly for the worst; the fact is, most mic preamps do one thing well and suite certain sources better than others.

When we initially discussed creating a mic preamp, we unanimously came to the same conclusion - we need to design one of the cleanest and most transparent preamps on the market; and that's what we did - and that's what you have in your hands.

Camden 500 is capable of being the most delicate and natural preamp you've ever heard as it exhibits the theoretical limits of EIN, THD, phase shift, and frequency roll-off performance. Acoustic guitars and strings sound like they are right next to you; vocals sound open, natural, and intimate; drums sound punchier and tighter than you have ever heard before.

We're musicians and engineers ourselves, and we know that there are moments when you want that extra bit of character. So, to compliment the clean and natural front end of Camden 500, we developed our discrete Mojo analogue saturation circuit that transforms Camden 500 into the fattest, warmest, and most characterful preamp in your arsenal at the turn of a dial. Mojo can be subtle, it can also be exaggerated, but best of all it can be bypassed.

To top it all off, each and every Camden 500 is proudly made with the utmost care and attention to detail by our team in the UK. The beauty of this is that each and every one of our products receives our strict quality-control procedure to ensure that every product meets our specifications without relying on offshore factories maintaining our strict high-standards on our behalf whilst being situated halfway across the world.

Camden 500 User Manual

Camden 500 - 500 Series Preamp And Signal Processor User Manual	1
Welcome to our family	2
Cranborne Audio Camden 500	3
Camden 500 User Manual	4
Getting Started	5
Controls, Switches, and Connectors	5
Feature Overview	6
Signal Flow	6
Input And Connections / Input Type Switch [F8]	6
Gain Control [F6]	7
Signal Indicators [F3]	8
48v Switch [F7]	8
48v Status Indicator [F9]	9
Polarity (∅) Switch [F5]	10
HPF Switch [F4]	10
Mojo	11
Mojo Control [F1]	11
Mojo Style Switch [F2]	11
Thump	12
Cream	13
Technical Specifications	14
Equivalent Input Noise	15
THD+N	16
Frequency Response	17
Phase Shift	18
Application Guides	19
Achieving Ideal Operating Level	20
Reamping Sources Through Mojo	21
Maximising Mojo	22
Troubleshooting	23
Important Safety Instructions	24
General Safety	24
Installation notes	24
Power Safety	25
CE Certification	25
FCC Certification	25
RoHS Notice	26
Instructions for disposal of WEEE by end users in the European Union	26
Electromagnetic Compatibility	26

Controls, Switches, and Connectors

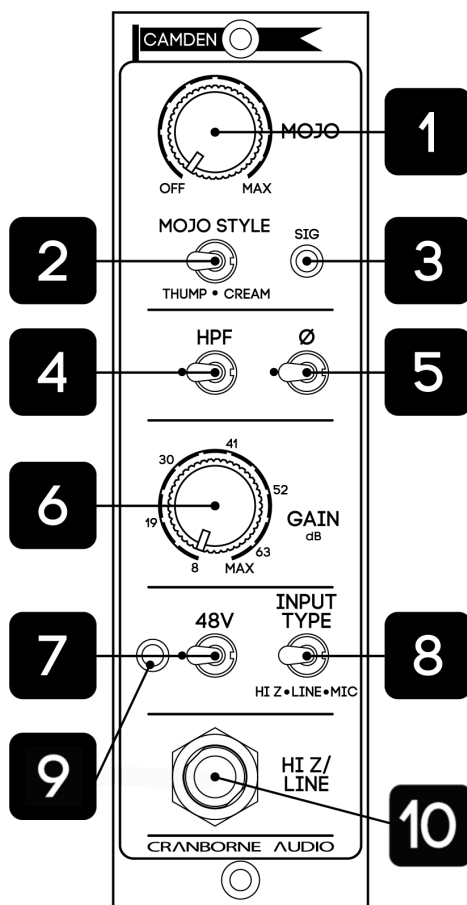

<p>[1] Mojo Control: Adjusts the level of Mojo analogue saturation. Bypasses Mojo and clicks off when it's turned fully anti-clockwise.</p>	<p>[6] Gain Control: 12 position switched pot. Adjusts the input sensitivity of the preamp from 8 to 68.5dB in 5.5dB increments.</p>
<p>[2] Mojo Style Switch: Toggles the Mojo style between 2 discrete styles: Thump & Cream.</p>	<p>[7] 48v Switch: Engages 48v phantom power for the rear XLR connector onboard the 500 series chassis being used with Camden 500.</p>
<p>[3] Signal Indicators: RGB LED that displays incoming signal level and clip status.</p>	<p>[8] Input Type Switch: 3-way switch. Adjusts the input Impedance and pad status of the preamp Input to match the desired input type; hi-z, line, or mic.</p>
<p>[4] HPF Switch: Engages the 80Hz High Pass (Low Cut) filter. -3dB @ 80Hz.</p>	<p>[9] 48v Status Indicator: Bicolour LED that displays 48v status. <u>Off</u> = 48v Off, voltage fully discharged <u>Amber</u> = 48v voltage charging/discharging <u>Red</u> = 48v fully charged</p>
<p>[5] Polarity Switch: Inverts the polarity of the input signal by 180°.</p>	<p>[10] Hi-Z/Line Input: Used to connect Line or Hi-Z instruments directly into the preamp's front panel. Front panel input interrupts rear XLR in hi-z and line modes.</p>

Feature Overview

Signal Flow



Input And Connections

When inserted into a 500 series chassis, Camden 500 has two possible input paths; one on the host chassis itself, and one on Camden 500's front panel. When connecting inputs, pay close attention to Camden 500's input type switch to ensure that the correct input pad and impedance settings are being used for your desired source.

Rear Input

The rear input can accept mic, line, and hi-z sources via XLR or Jack depending on the host 500 series chassis being used.

Front Input

The front input can accept balanced line or unbalanced/balanced hi-z sources via ¼" jack. Microphones cannot be connected directly to the ¼" jack input on the front of Camden 500.

Input Type Switch [8]

The Input type switch **[8]** configures the front-end of Camden 500 to create the best possible environment for mic, line, and hi-z sources. Each switch position determines the input impedance, active input connector, and pad status of the preamp for each input type setting.

Mic

Switches Camden 500's input impedance to 8.9kOhms 48v Off, 5.4kOhms 48v ON. Mic input type has a maximum input level of 17.6dBu.

Line

Switches Camden 500's input impedance to 23.4kOhms and engages the -8dB pad. The line mode has a maximum input level of 26.5dBu.

Hi-Z

Switches Camden 500's input impedance to 1.5MOhms unbalanced, 3MOhms balanced. The Hi-Z mode has a maximum input level of 24dBu.

Gain Control [F6]

The Gain control **[F6]** is used to adjust the input sensitivity of the preamp to boost incoming signals to optimum operating level and achieve the best signal-to-noise ratio. The gain control is a 12-position, stepped-switch that adjusts the input sensitivity in steps of 5.5dB.

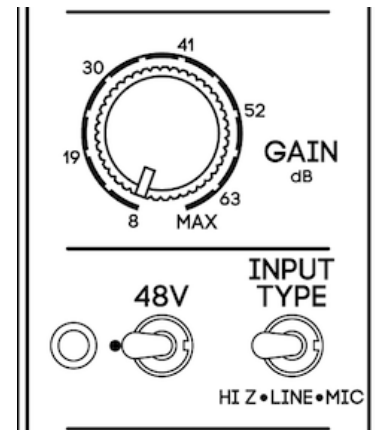

Mic Mode Gain Range

Position	Min	2	3	4	5	6	7	8	9	10	11	Max
Gain (dB)	8	13.5	19	24	30	35.5	41	46.5	52	57.5	63	68.5

Line Mode Gain Range

In line mode, Camden 500 engages an 8dB pad to enable a maximum input level of +26.5dBu and a gain range of 0dB to 60.5dB in 5.5dB steps.

Position	Min	2	3	4	5	6	7	8	9	10	11	Max
Gain (dB)	0	5.5	11	16.5	22	35.5	33	38.5	44	49.5	55	60.5

Hi-Z Mode Gain Range

Position	Min	2	3	4	5	6	7	8	9	10	11	Max
Gain (dB)	0	5.5	11	16.5	22	35.5	33	38.5	44	49.5	55	60.5

Signal Indicator [F3]

The signal indicator **[F3]** is a visual aid to help achieve the best performance and highest possible signal-to-noise ratio during the recording process. Correct gain staging will also get Mojo working at its best.

The signal LED is an RGB LED and is calibrated to have the following thresholds for input level:

Blue	-40dBu to -1dBu
Green	0dBu to +20dBu
Amber	+21dBu to +23dBu
Red (clip)	+24dBu

Tip:

To get the maximum effect out of Camden 500's Mojo control, the Gain Control should be run as high as possible without the Signal Indicator lighting RED.

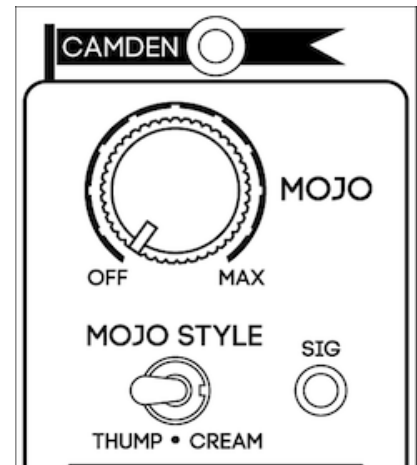

48v Switch [F7]

The 48v switch **[F7]** engages 48v phantom power and sends supply voltage down pin 1 of the chassis' XLR input socket to power condenser microphones and Di boxes if required. Phantom power is off when in the 'right' position. Phantom power is on and ready when in the 'left' position and the LED is lit up red.

Note:

Do not engage 48v with vintage ribbon mics connected to Camden 500 as sending voltages through to the ribbon can cause permanent damage to the microphone.

Be careful when connecting line-level instruments (such as interfaces, keyboards) to Camden 500 via XLR when 48v is engaged. Sending 48v through to the line-level outputs of instruments and playback devices can cause irreparable damage to their internal components and is not covered under warranty.

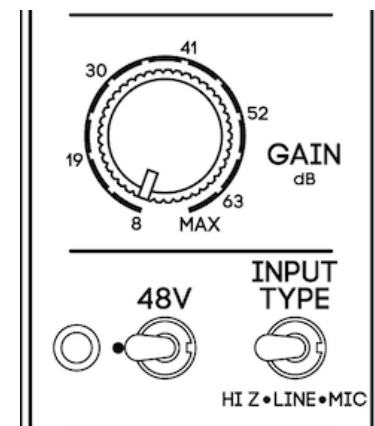

48v Status Indicator [F9]

The 48v Status LED [F9] is a Bicolour LED that displays the full 48v status of the preamp. Due to the design of Camden 500 preamps and its internal circuitry, the 48v can take a while to charge and discharge during use. As a safety feature and to prevent damage to your microphones, Camden 500 displays the voltage status of the 48v using a 3rd, 'Amber', colour.

Off	48v Off, voltage fully discharged
Amber	48v voltage charging/discharging
Red	48v fully charged

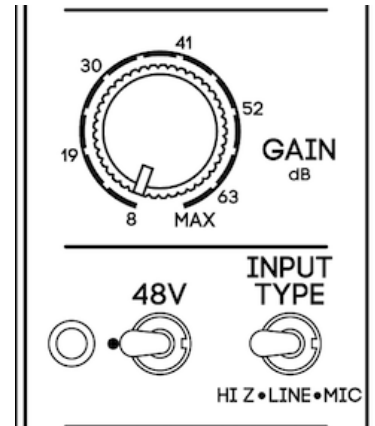

Engaging 48v

When first engaged, the 48v Status Indicator LED lights Amber whilst the voltage is reaching the full 48v. During this time, do not adjust the Gain control as doing so may cause pops and clicks through the preamp output as the caps are still charging.

When the 48v Status Indicator lights RED, the 48v is fully charged and the preamp is ready for use.

Disengaging 48v

When disengaged, the 48v Status Indicator LED lights Amber whilst current is discharged from the XLR connector. During this time, do not disconnect the microphone/DI Box or connect a ribbon mics to the XLR as voltage is still present.

Once the LED has turned off, there is no longer any voltage present on the XLR connector and the preamp is ready to use.

Note:

Some microphones may take longer to charge/discharge than others and so the duration of the Amber LED status may change depending on what device is being used.



Warning:

Do not connect/disconnect microphones from Camden 500 when 48v Phantom Power is engaged as doing so could cause damage to Camden 500 or your connected microphone. Damage caused during improper 48v usage is not covered under warranty.

Polarity (Ø) Switch [F5]

The Polarity Switch **[F5]** inverts the polarity of the incoming audio by 180° in order to optimise the phase interaction of the preamp's signal with other audio tracks also being recorded.

Tip:

In isolation, flipping the polarity of the mic preamp will not result in any audible effects, however the polarity switch is a useful tool when Camden 500 is being used as part of a multi-mic recording setup, or instances where other instruments - also being mic'd and recorded - are bleeding into the microphone.

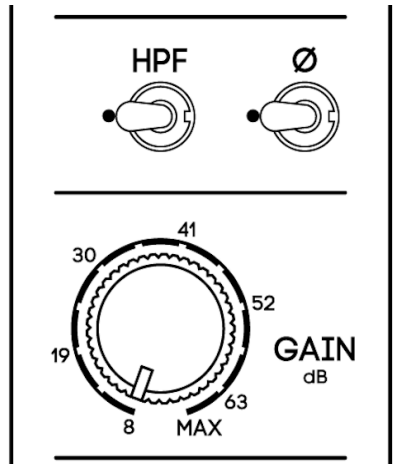

HPF Switch [F4]

The HPF Switch **[F4]** engages a filter that removes low-end rumble from sources that do not require low frequency extension. The filter is set to achieve 3dB of attenuation at 80Hz and features a 12dB per octave slope.

Camden 500's High Pass Filter has been tuned to achieve a smoother onset but more dramatic roll-off than standard filters resulting in a more natural-sounding low-frequency attenuation.

Tip:

As the HPF is positioned after the Mojo circuit in the signal path it can also be used in conjunction with Mojo to create even more tonal-shaping possibilities.

Try using Thump on a vocal track alongside the HPF to introduce rich and intimate low-mid harmonics without excessive plosive or rumble effects in the lower frequencies.

Try using Cream on an electric guitar mic alongside the HPF to achieve more high-mid harmonic focus. Dynamically remove mid-range boxiness, allowing the guitar to cut through a mix whilst using the HPF to trim the low-end 'woof' coming from the cabinet itself.

Mojo

A perfectly clean preamp is great for capturing sources that need the utmost clarity and detail, however, being audio engineers and musicians ourselves - we know that some of the best records ever made had grit, character, and were recorded on preamps that imparted their own colour onto the signal - that's the sound we all hear when we say the word 'vintage'.

Transformers are big, bold, and impart a lot of character onto the sound. Both vintage and modern equipment feature transformers and they can sound great... but transformers can often cause issues. Transformers are noisy, they exhibit huge phase shifts - as much 90° at 50Hz (which equates to 5ms) - and they impart an EQ onto the audio.



Also, as transformers are integral to the way that a preamp works - they cannot be bypassed to reveal the pure signal. Our Mojo circuit is an analogue emulation of the desirable effects of transformers but without the downsides such as dramatic phase shifts and excess noise. Unlike transformer-based designs, Mojo's effects live on a variable control that can be dialed to taste on some sources, and bypassed for others.

We built a brand-new type of saturation circuit consisting of an array of different filters (some of which are inductive) and discrete second and third order harmonic generators that allow precise emulation of the saturation and low-end reinforcement behaviours of vintage equipment. Mojo can even be dialed-in to well-beyond the point that destructive clipping would usually occur with transformer-based designs for a wider palette of saturation effects.

By manipulating these filters and harmonic generators; we can create two discrete Mojo styles; Cream and Thump - both turn the impeccably clean and transparent Camden topology into the fattest, warmest, and most characterful preamp in your arsenal - all at the turn of a dial.

Mojo Control [F1]

The Mojo Control **[F1]** adjusts the level of the Mojo effect that is being mixed-in with the dry signal. The pot is variable to enable the best possible blend of the Mojo character to be dialed-in. When turned fully anti-clockwise, the pot switches off in order to completely bypass Mojo from the signal path.

Mojo Style Switch [F2]

The Mojo Style Switch **[F2]** selects which Mojo circuit is currently active; Thump or Cream. Each Mojo style suits a variety of different instruments in different ways and for different effects.

Thump

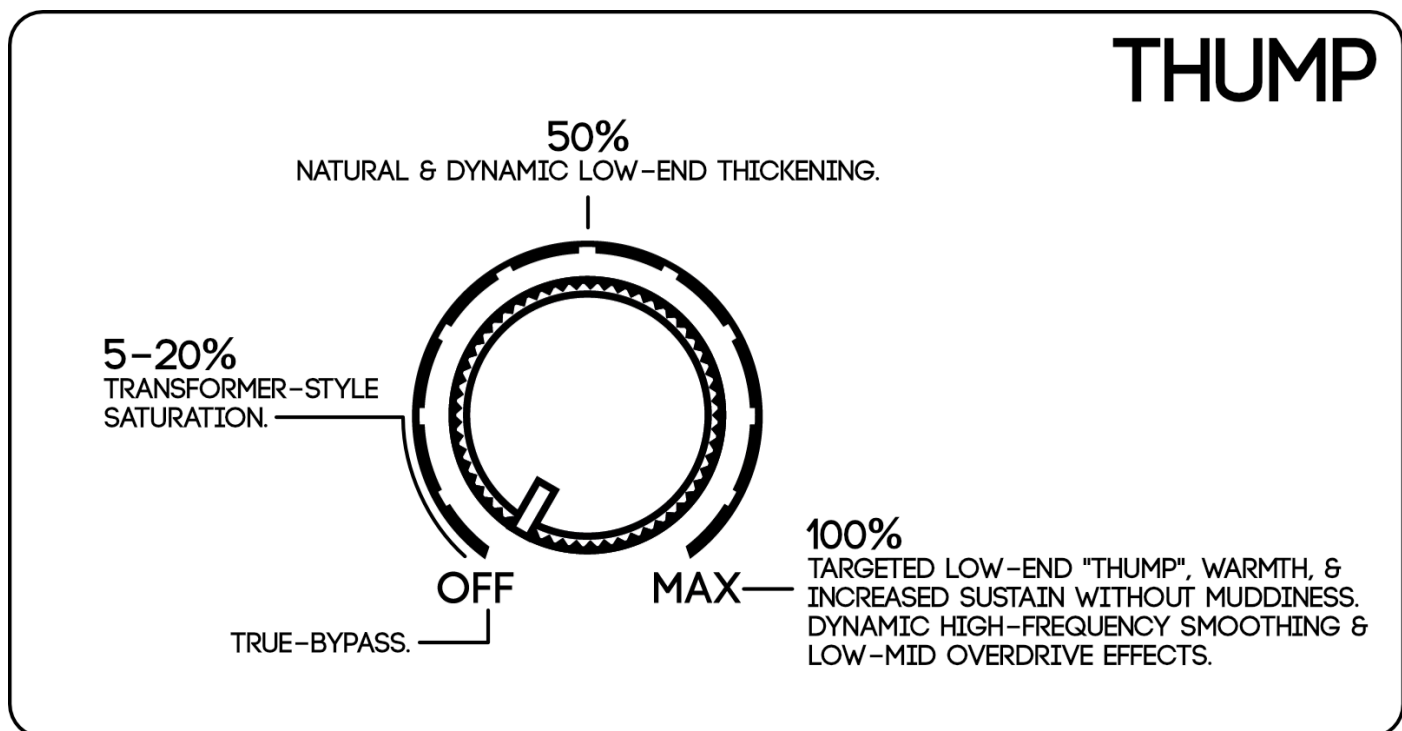

Thump is a style that works best on - but is not limited to - low-frequency based instruments. Thump excites low-end content by boosting harmonics in the range of ~100Hz to 20Hz and below without increasing the fundamental frequencies - resulting in fuller low-end on all reproduction mediums. As Thump is not EQ-based, the additional harmonic content is shaped by the source and it's existing low-end frequency content resulting in a natural addition of extra "Thump". Similar-sounding EQ moves will result in extreme wooliness as all sonic energy is boosted - even unwanted audio in-between the hits.

On sources such Kick drum, Thump will add the desired amount of low-end thickness required to provide the foundation for the rest of the mix to sit on. As Thump is NOT EQ-based, the content added is controlled by the hits unlike EQ.

On Snare, Vocals, and Guitar - sources that are traditionally filtered at around 80Hz - Thump can still be used in conjunction with the Camden's HPF to add low harmonics to the low-mid frequencies without adding extraneous low-end that could cause havoc during the mix phase.

Cream

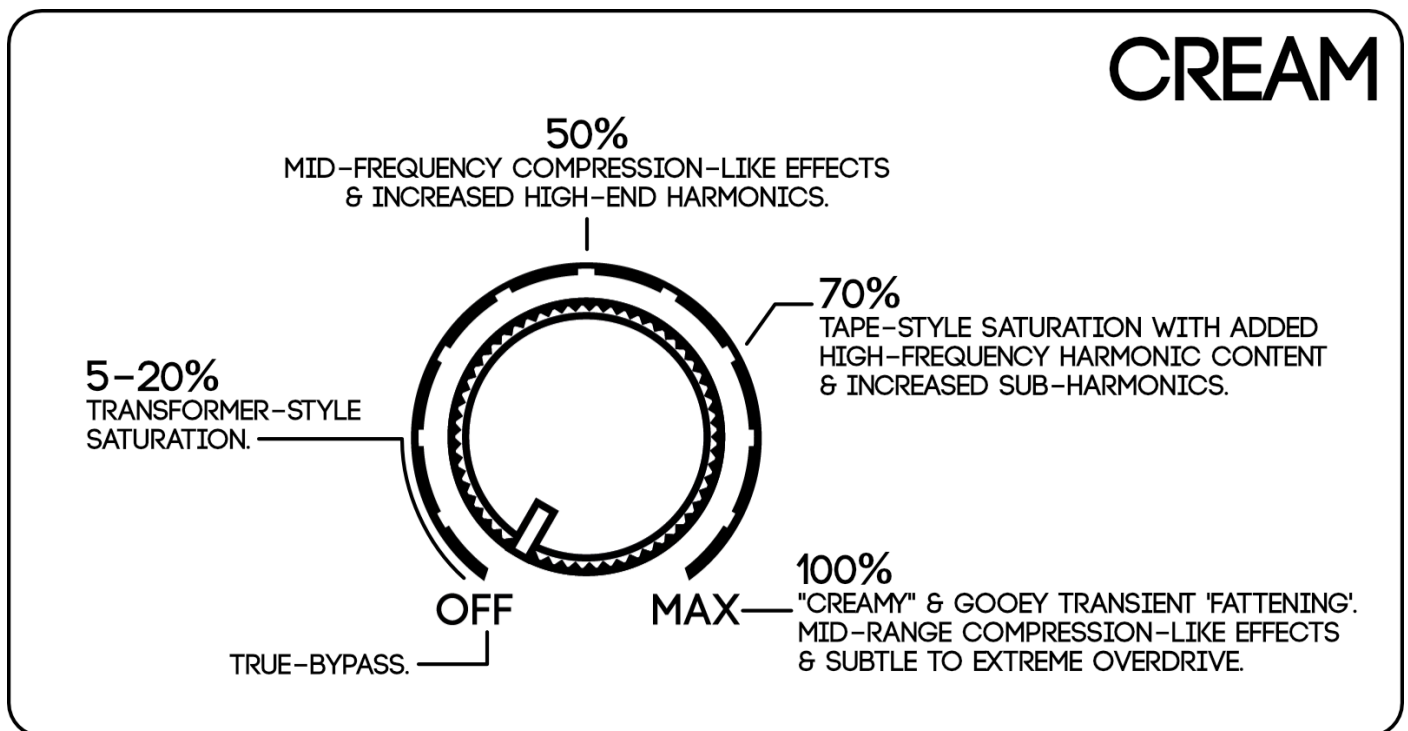

Cream introduces a vintage smoothness that enables tracks to sit deep within a complex mix in a way that cannot be replicated with EQ. The Cream setting drastically increases THD whilst smoothing out the low-mids.

As with Thump, Cream is not EQ based and is achieved by blending 2 saturation stages with the dry signal and additional harmonics. Cream varies entirely on the harmonic signature of the incoming source. It will increase high-end forwardness and create unique harmonic-based tonal shaping effects on mid-range instruments, but it will also add low-end on full range sources as well as unique "compression-style" effect on transients.

On vocals, a delicate amount of Cream will add high-end harmonics that will bring the vocals forward whilst also taming the midrange 'honkiness' of an unprocessed vocal track. Higher Cream settings will take a clean vocal track through to a warm vintage saturation with subtle overdrive effects that have the effect of smoothing-out 'esses' and adding up-front warmth.

On drums you will notice a 'fattening' of transients resulting in more emphasis on the sustain and shell of the drum itself as well as a subtle low-end boost. Overheads in particular will sound as if they were recorded in a bigger room.

On distorted electric guitars, a generous amount of Cream will turn a dull recording into a speaker-busting, harmonically rich, mix-cutting masterpiece that stands shoulder to shoulder with any commercial recording.

Technical Specifications

When we set out to design Camden 500, we decided that we wanted to bring the kind of sonic performance previously reserved for those with the highest budgets to everyday musicians and engineers - people just like ourselves.

Put simply, Camden 500 is one of the cleanest, most linear, and transparent preamps you've ever heard. These are very bold claims... but they're not claims that we would make lightly. Below, we're going to dive into the technical specifications and show you some performance graphs that demonstrate what we mean.

<i>All specifications were generated using an Audio Precision APx555, Camden 500 pre-production unit, and 500R8 prototype. Camden 500 specifications will vary depending on the specifications of the 500 series rack used. All specifications are subject to change at</i>	
Minimum Gain: Mic= 8dB, Line = 0dB, Hi-Z = 3dB	Maximum Gain: Mic = 68dB, Line = 60dB, Hi-Z = 63dB
Input Impedance: Mic= 8.9kOhms 48v Off, 5.4kOhms 48v ON, Line = 24.3kOhms Hi-Z= 1.5MOhm unbalanced, 3MOhm balanced	Max Input Level: Mic = 17.6dBu (<0.003%) Line = 26.5dBu (<0.02% THD) Hi-Z = 24dBu (<0.02% THD)
Output Impedance: 150 Ohms	Max Output Level: 27.5dBu (<0.002% THD, 30dB gain)
Equivalent Input Noise (EIN): <-129.5dBu, 150 ohm source, unweighted <-131dBu, 150 ohm source, A-weighted <-135.5dBu, Inputs common, unweighted	Frequency Response: ±0.25dB, <5 Hz to >200 kHz, 35dB gain ±1dB, <5 Hz to >200 kHz, max gain
Phase Shift: <2.25°, 40dB gain, 20Hz to 20kHz <4°, Max gain, 20Hz to 20kHz	THD+N: <0.0004%, 1kHz, 35dB gain, 24dBu out
Intermodulation Distortion: <0.0008%, 50Hz and 7kHz, 35dB gain, 20dBu out <0.0006%, 50Hz and 7kHz, 35dB gain, 15dBu out	HPF: 80Hz, -3dB, 12dB/Oct
Current Draw: 120mA per rail - idle 140mA per rail - typical use case	CMRR: >70dB, typ >85dB, 35dB gain, 10-20kHz, 100mV Common mode
Slew Rate: 20V/uS, 35dB gain, 25dBu out	Dimensions (mm): 31.8/133.35/170.11 (w/h/d)

Equivalent Input Noise

Equivalent Input Noise or EIN, measures the noise that the preamp adds onto an input signal. The lower the EIN, the greater the signal-to-noise ratio and the more processing you can apply in your DAW without fear of preamp noise masking an intricate performance.

EIN can be measured in different ways. We prefer using an “unweighted” measurement with a 150 ohm load because this measurement is the most indicative of the performance achieved with a microphone, instrument, or line input (a load). Other manufacturers may represent an EIN value such as “inputs common”, “inputs shorted” or “A-weighting” on their EIN figures - these measurement techniques will achieve lower numbers but will be less revealing as to what the noise performance will actually be with an input connected. Camden 500 has an EIN of -129.5dB unweighted with a 150 ohm load.

If we use other measurement techniques such as “inputs common” or “A-weighting” - Camden’s EIN performance is <-135.5dB, and <-131dB respectively. The result is an ultra low-noise front-end that you would only find on the most elite and expensive mic preamps.

Additionally, an important aspect to consider when evaluating EIN and noise performance of preamps is that most manufacturers only site the EIN at one particular gain setting - usually where the performance is best. But the EIN can change dramatically at different gain settings of a preamp. But not so for the Camden - the Camden achieves the same EIN performance at all gain positions.

THD+N

Total harmonic distortion or THD is what gives a preamp a 'sound' or 'colour'. It's a measurement of the harmonic content that is generated by the preamp and added onto an input signal. Highly-regarded "warm" or "vintage" mic preamps will have lots of THD from its transformers or valves to give its sound. But equally, THD can sound "bad" like in the case of many entry-level mic preamps when the source of the THD is transistor distortion and similar.

As such, the sound of THD is very subjective. However, what is objective with THD measurements is the smaller the THD percentage, the more transparent the mic preamp and the less colour - good or bad - it is adding to the signal. When designing Camden 500 - we aimed for the smallest possible THD percentage to achieve the most transparent preamp possible.

Camden 500's THD+N remains inaudible and below 0.02% at all frequencies and gain positions. THD+N reaches 0.0002% (1kHz) at 24.5dB gain, and remains below 0.0008% (1kHz) at all gain positions from 8dB to 46.5dB. THD+N is often measured by other manufacturers at one gain setting and one frequency - usually where the best number is achieved.

But THD can vary significantly at different frequencies and gain positions - but not with Camden 500. Throughout all gain positions, Camden 500's THD is completely inaudible meaning complete transparency at all gain settings and all frequencies - unless it has been applied using Mojo.

THD+N RATIO: ALL GAIN SETTINGS

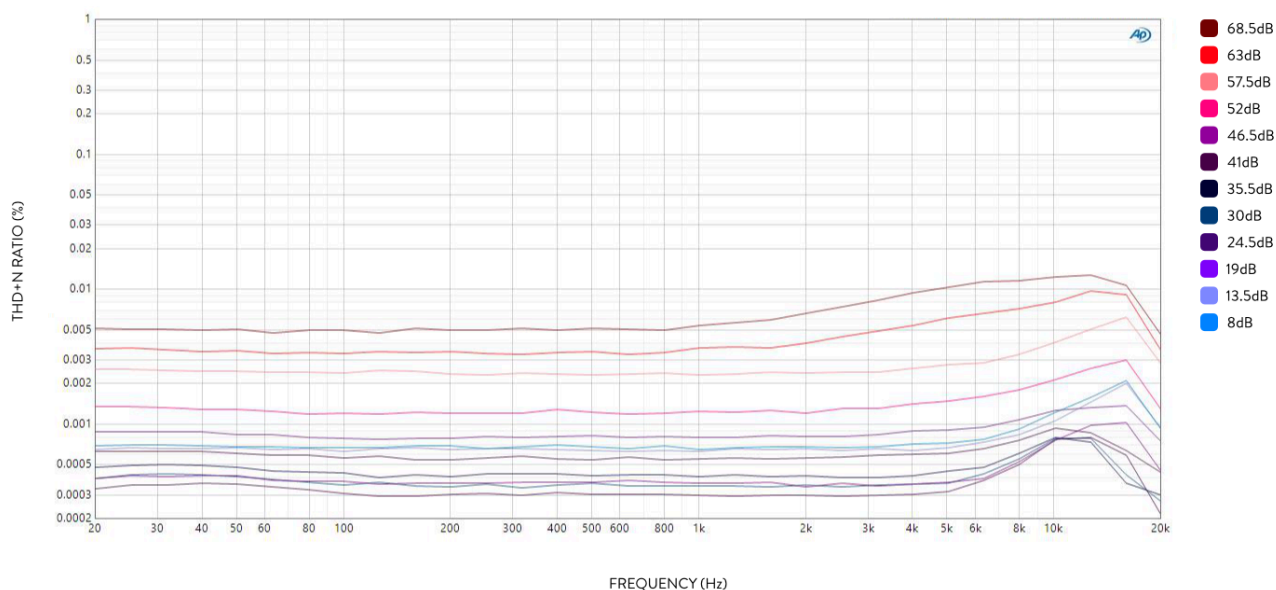

Frequency Response

The brand new Camden topology sets new standards for frequency and phase linearity within the audio band and well beyond. Camden 500's frequency response remains linear within 0.7dB from 5Hz to 200kHz at all gain settings.

Maintaining an extended frequency bandwidth dramatically reduces intermodulation distortion and other complex interactions finding their way into the audio band and causing high-end smearing and 'hype'. A typical preamp can begin rolling-off frequencies above 20kHz which makes them susceptible to a harsh and unnatural high-end character.

Preamps also tend to drastically increase frequency roll-off as the gain is increased to maximum, however Camden 500 only has a maximum roll-off of 0.7dB for a consistently linear frequency response at all gain settings - resulting in crystal clear, detailed, and accurate high end that is impervious to increased intermodulation distortion as gain is increased.

FREQUENCY RESPONSE: ALL GAIN SETTINGS

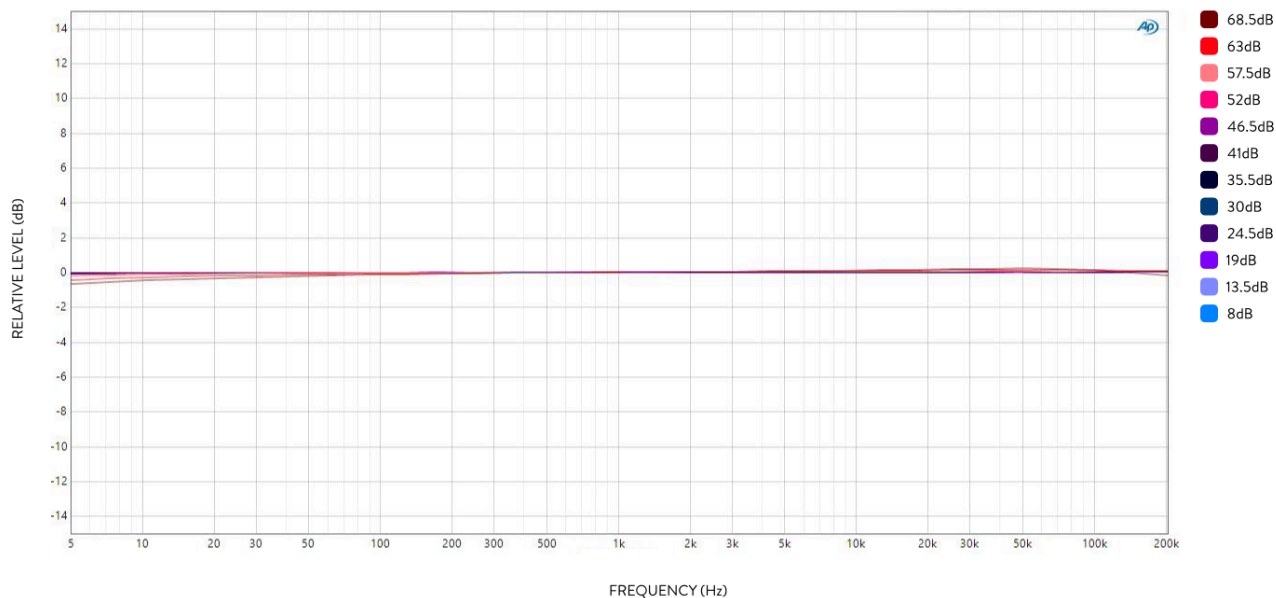

Phase Shift

Phase shift means that certain frequencies are delayed when they are amplified by a preamp - they can result in sluggish transients, a lack of punchiness, and tonal colouration. Vintage 1073-style preamps can exhibit as much as 90° of phase shift at 50Hz - this essentially means that 50Hz arrives at your ears 5ms after the initial transient.

Whilst this character can be attributed to being part of the sound and colouration that we want in these vintage-style preamps, it can also be the root cause of a lot of undesirable effects when used in multi-mic setups and when trying to capture clean and pure audio signals; audible effects that cannot be remedied by flipping the polarity or aligning transients in post-production.

Camden 500's phase shift remains below 2.25° between 20Hz-20kHz up to 57.5dB of gain. This allows Camden 500 to produce punchy, sharp, and tight transients at all frequencies and on all sources without fear of reduced attack as gain is increased. At maximum gain, Camden 500's phase shift increases to only 4° - an unprecedented figure for a preamp at maximum gain.

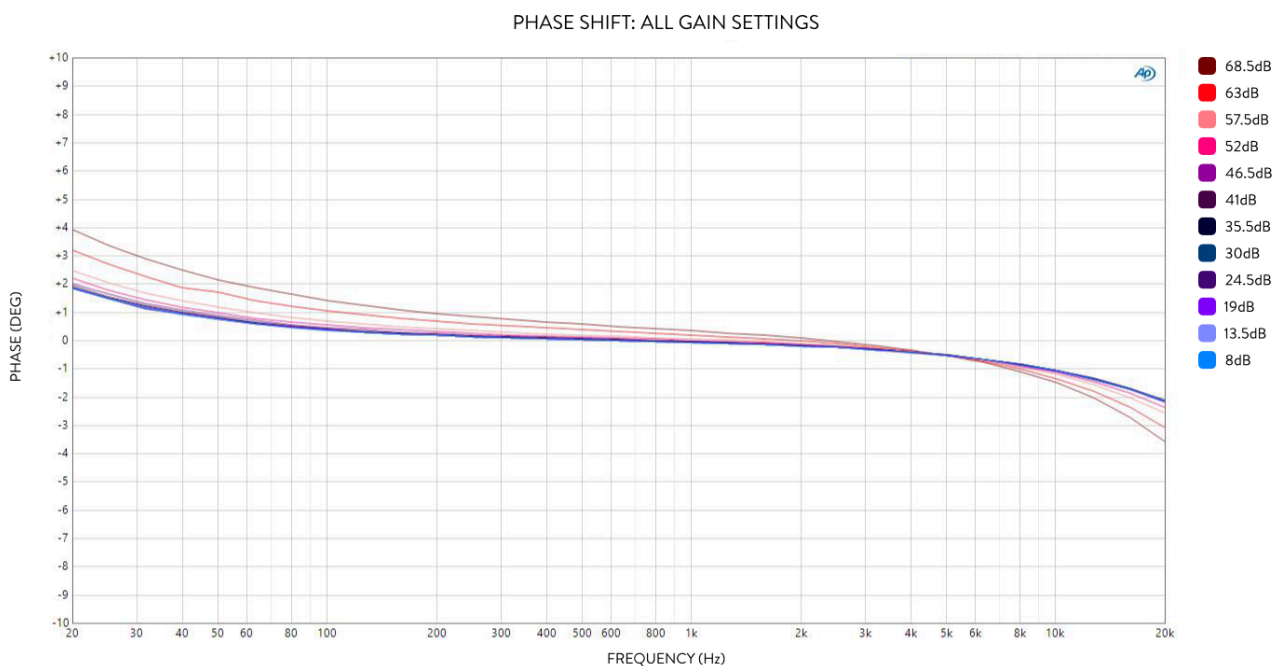

Application Guides

Achieving Ideal Operating Level

In order to achieve the optimum signal-to-noise-ratio, get the most out of the on-board Mojo processing, and retain our published specifications; Camden 500 should be run as 'hot' as possible before the LED clip indicator lights up consistently.

The best way to do that is as follows:

- 1) Insert your desired source into Camden 500's input connections.
- 2) With your source playing at the correct level/velocity, Increase Camden 500's gain control until the signal Indicator is displaying a strong and bright signal and the Clip indicator only gently and occasionally lights up when the loudest transients are reached.
- 3) Ensure that the recording device connected to Camden 500 is set correctly.
 - If you are sending the output of Camden 500 into an audio interface's line input, make sure that the line input is set to +4dBu reference level and any input gain control is set to its minimum setting.

You should now be receiving a healthy level into Camden 500 and onwards to your audio interface. If the preamp begins to clip during the recording process, reduce the input gain control accordingly.

Note:

Camden 500's maximum output level is +27.5dBu however most audio interfaces have a maximum input level of +21.5dBu; it is very easy for Camden 500 to clip the input of an audio interface if the gain controls are not set correctly. If additional attenuation is required between Camden 500 and your audio interface, then you can purchase an external PAD to bring the output level down to a usable range for your desired audio interface.

Reamping Sources Through Mojo

Camden 500 is more than just a preamp; it's also a signal processor featuring our Mojo circuit. The great thing about Mojo is that it is an amazing analogue saturation tool that can be used on anything from the beginning (tracking) to the end of your music creation (mixing, parallel effects, summing) process.

By reamping, you can insert the Mojo control across a single track, group, or entire mix coming from your DAW using your audio interface. For this example we will use a single Kick drum track, however the same process applies for any source.

1. Using your DAW, assign the output of the kick track to be sent out of an unused, physical line output of your audio interface.
 - Consult the user manual of your DAW to find the exact facility for outputting channels to hardware outputs of your interface - All DAW's do this differently.
2. Connect the physical output of the audio interface into the input of Camden 500.
3. On Camden 500's front panel, switch the input type switch to line, and reduce the gain control to its minimum setting.
4. With the DAW playing and audio being sent out of your interface, increase the gain control of Camden 500 until the Green LED is lighting brightly and the Clip indicator only gently lights up when the loudest transients are reached.
5. Connect the output of Camden 500 to a spare line-Input on your audio interface.
6. Using your audio interface, monitor Camden 500 by using your speakers or your headphone outputs
 - All systems will do this different by monitoring through the DAW directly, or through a custom mixer control panel.
7. Select the desired Mojo style (Thump/Cream) and turn the Mojo control clockwise until the pot switches on and you begin hearing the effect of Mojo on the signal - then dial Mojo to taste.

Once the Mojo has been dialled to taste, you are ready to re-record the affected signal back into your DAW:

8. Create a new track within your DAW and assign the input of the track to be the input that Camden 500 is connected to on your audio interface.
9. Record-enable the DAW track and mute its output.
10. Rewind the DAW to the start of the Kick drum track and press the master record button to begin recording.

Once the recording process has stopped, you will now have a new Kick drum track that features your desired Mojo processing and can be used in-place of the original audio file during the mix phase. At this point, it's a good idea to level match and A/B the Dry and Mojo tracks to hear the effects of Mojo for yourself!

Maximising Mojo

Mojo is harmonic-based tone shaping tool. Mojo's effect varies entirely on the sonic signature of the audio that is being sent into the cascading overdrive and discrete harmonic generation circuits. The level, frequency, and dynamic range of the incoming audio will organically change Mojo and increase/decrease the effect. With this in mind, there are a few little tricks and ideas that you can use to achieve different results from Mojo that might better-suit your desired source.

Applying Mojo Pre Or Post Processing

The effects of mojo can change drastically depending on if Mojo is applied to a signal pre or post processing. If an uncompressed signal is sent through Mojo set to Cream, the mid range compression effect will take place as the performance varies in amplitude and mid range content, however If a compressed signal is sent through Cream then its effects will be more consistent and less dynamic.

Applying EQ after audio has been processed through Mojo allows accentuation of the additional harmonic content and detail, however applying EQ before processing with Mojo allows more control over what frequencies are influencing the harmonic effects of Mojo; filter-out low frequencies pre-mojo to determine what frequencies Thump will target or filter after Mojo to retain Thump's harmonic additions whilst reducing LF rumble.

Cascading Mojo

Cream and Thump work perfectly in isolation however when used together, they can provide even more tonal shaping possibilities to turn raw, unprocessed audio files into warm, rich, and analogue-sounding goodness that will sit nicely into the mix and require minimal further processing. Cascading Mojo circuits does not always require two individual modules (although it can make the processes simpler!).

Thanks to Camden 500's high-headroom line input and low-noise design, you can run audio already processed by Thump or Cream, back-through Camden 500 to apply a second stage of processing and re-record its effects back into the DAW. Even cascading audio into two instances of the same Mojo style can offer-up a greater range of tonal options. Two instances of Thump will increase low-end 2nd/3rd order harmonics whilst still remaining tight and focused, without excess Mud.

As the amplitude of the fundamental frequencies are not affected with Mojo, the audio does not increase in perceived volume but the increased harmonics can lead to interesting low-mid overdrive effects that can instantly warm-up stems, groups, or mixes in a way that is not possible with EQ's but it synonymous with classic 'british' mixing consoles.

There are no rules when it comes to Mojo! Give it a go and see what happens!

During our development phase, we tested Mojo extensively by running all of the audio stems we could find through it in order to hone-in on the exact circuit design that would suit the most amount of sources. During this process we found out some very interesting results... having the ability to bypass the Mojo effect meant that we could really hear what the 'transformer' would do to that signal; on circuits where transformers cannot be bypassed, it's difficult to know what you're gaining sonically by using that preamp design. Ultimately, this is a very personal topic, but we wanted to share with you some of the most dramatic results that we came across when we were developing Mojo and testing it on a bunch of different sources. Some of our results surprised us - they might surprise you too!

Thump	<p>Drum Overheads Increased low-end sustain and fatter transients. Smoother High-end.</p> <p>Overdriven Guitars Smoother overdrive sounds with more saturation, reduce rumble using HPF.</p> <p>Kick Increased sustain with clean transients.</p> <p>Snare Top More shell-body and smoother highs and less brittleness.</p> <p>Toms Richer low-end without increasing ring-out in-between hits.</p> <p>Vocals Smooth and more intimate low-end, reduce plosives with HPF. Apply Mojo after compression for different results.</p> <p>Bass Di Fuller lows and low-mids with impressive, amp-like depth.</p> <p>Piano Stronger undertones and more consistent frequency response throughout the piano's range.</p> <p>Programmed Instruments Improved low-end content and dynamics. Mojo adds an element of realism to programmed drums especially.</p>
Cream	<p>Room Mics Increased room size, less boxiness on drum rooms especially.</p> <p>Electric Guitar Increased high-end harmonic content and more open high-mid reduce rumble using HPF.</p> <p>Acoustic Guitar Improved intricacy in the high-end, increased HF blooming. Can exhibit subtle vintage overdrive effects</p> <p>Snare Bottom Light 'compression-like' effects in boxy frequencies and increased high-mid harmonic content. Reduce kick bleed with HPF. Perfect when blended with a Snare Top being sent through Thump.</p> <p>Brass & Woodwind Improved cut and harmonic content, Saxophone especially comes alive.</p> <p>Organ & Rhoads Improved cut and harmonic content.</p> <p>Vocals Smoother frequencies on dynamic phrases and accentuation of upper harmonics. Slight de-essing effects with a less-prominent low-mid 'boxiness'</p>

Troubleshooting

Issue	Solution(s)
Why can't I hear the effects of Mojo?	<p>Check your gain staging and ensure Camden 500 is set to the highest possible gain setting before clipping.</p> <ul style="list-style-type: none"> ● Turn the Mojo control clockwise until the control 'switches' on - then dial to taste. ● Occasionally, some sources will not feature enough frequency content to enable Mojo to take effect. In these rare circumstances treat the audio with another type of processing.
Why is there 'clicking' and 'popping' when I adjust the gain control?	<ul style="list-style-type: none"> ● When Camden 500 is powered up, it can take between 10-30 seconds for the bias points to fully settle. During this time, the preamp can exhibit mild 'clicking' noises when the gain control is adjusted. These noises are nothing to worry about and will become inaudible once the preamp is fully powered up.
Why can I hear hiss when I turn the gain control to full?	<ul style="list-style-type: none"> ● Hiss can be caused by a number of factors - many of which are nothing to do with the preamp and could be entering the signal before Camden 500. ● Check the microphone itself and see if the noise follows the preamp or mic. ● Ensure that the input connectors of Camden 500 are loaded (ie, connected to a mic, line, or instrument source) before raising the gain. Unloaded XLR or Jack connectors can exhibit their own noise and is not an accurate measure of preamp performance.
Why is the rear XLR socket not working?	<ul style="list-style-type: none"> ● Ensure that the front 1/4" jack is not connected. ● Ensure Camden 500 is seated correctly within the 500-series backplane connector. ● Consult the manufacturers of your 500-series rack - the XLR connector or backplane could be faulty.

Important Safety Instructions

General Safety

- Read these instructions carefully
- Keep these instructions
- Heed all warnings
- Follow all instructions
- Do not use this apparatus near water
- Clean only with a dry cloth
- Do not block any ventilation openings and install in accordance with the manufacturer's instructions.
- Do not install near any heat sources such as radiators, heat registers, stoves or other apparatus (including amplifiers) that produce heat.
- Do not defeat the safety purpose or grounding-type plug. A polarized plug has two blades with one wider than the other. A grounding type plug has two blades with a third grounding prong. The wide blade or the 3rd prong are provided for your safety. If the provided plug does not fit your outlet, consult an electrician for replacement of the obsolete outlet.
- Protect the power cord from being walked on or pinched particularly at plugs, convenience receptacles, and the point where they exit from the apparatus.
- Only use attachments/accessories recommended by the manufacturer.
- Unplug this apparatus during lightning storms or when unused for long periods of time.
- Refer all servicing to qualified service personnel. Servicing is required when the apparatus has been damaged in any way, such as power-supply cord or plug is damaged, liquid has been spilled or objects have fallen into the apparatus, the apparatus has been exposed to rain or moisture, does not operate normally, or has been dropped.
- Do NOT modify this unit, alterations may affect performance, safety and/or international compliance standards.
- Cranborne Audio does not accept liability for damage caused by maintenance, repair or modification by unauthorized personnel.

Installation notes

- When installing the apparatus either fit it into a standard 19" rack or place it on a secure level surface.
- If the unit is rack mounted, fit all rack screws.
- When rack mounting, allow a 1U gap above and below the unit for cooling.
- Ensure that no strain is placed on any cables connected to this apparatus. Ensure that all such cables are not placed where they can be stepped on, pulled, or tripped over.



WARNING: To reduce the risk of fire or electric shock, do not expose this apparatus to rain or moisture.

ATTENTION: Afin de réduire les risques de choc électrique, ne pas exposer cet appareil à l'humidité ou à la pluie.

Power Safety

- The unit is supplied with an external power supply and suitable mains lead. Only use the supplied external power supply, however if you decide to use a mains lead of your choice, bear in mind the following:
 - Refer to the rating label of the unit and always use a suitable mains cords.
 - The unit should ALWAYS be earthed with the earth on the IEC socket.
 - Please use compliant 60320 C13 TYPE SOCKET. When connecting to supply outlets ensure that appropriate sized conductors and plugs are used to suit local electrical requirements.
 - Maximum cord length should be 4.5m (15')
 - The cord should bear the approval mark of the country it is to be used.
- Connect only to an AC power source that contains a protective earthing (PE) conductor.
- Only connect unit to single phase supplies with the neutral conductor at earth potential.

GB The apparatus shall be connected to mains socket outlets with a protective earthing connection.

DEN Apparatets stikprop skal tilsluttes en stikkontakt med jord, som giver forbindelse til stikproppens jord.

FIN Laite on liitettävä sojamaadoituskoskettimilla varustettuun pistorasiaan.

NOR Apparatet må tilkoples jordet stikkontakt.

SWE Apparaten skall anslutas till jordat uttag.



ATTENTION: Un-earthed metal parts may be present inside the enclosure. No user serviceable parts inside - to be serviced only by qualified personnel. When servicing, disconnect all power sources before removing any panels.

CE Certification



This unit is CE compliant. Note that any cables supplied with Cranborne Audio equipment may be fitted with ferrite rings at each end. This is to comply with the current regulations and these ferrites should not be removed.

FCC Certification

- Do not modify this unit! This product, when installed as indicated in the instructions contained in the installation manual, meets FCC requirements.
- Important: this product satisfies FCC regulations when high quality shielded cables are used to connect with other equipment. Failure to use high quality shielded cables or to follow the installation instructions may cause magnetic interference appliances such as radios televisions and will void your FCC authorisation to use this product in the USA.
- This equipment has been tested and found to comply with the limits for a Class B digital device, pursuant to part 15 of FCC rules. These limits are designed to provide reasonable protection against harmful interference when the equipment is operated in a commercial environment. This equipment generates, uses, and can radiate radio frequency energy and if not installed and used in accordance with the instruction manual may cause harmful interference to radio communications. Operation of this equipment in a residential area is likely to cause harmful interference in which case the user will be required to correct the interference at their own expense.

RoHS Notice

Cranborne Audio complies with and this product conforms to European Union's directive 2011/165/EU on Restrictions of Hazardous Substances (RoHS) as well as the following sections of California law which refer to RoHS, namely sections 25214.10, 25214.10.2, and 58012, Health and Safety Code Section 42475.2, Public Resources Code.

Instructions for disposal of WEEE by end users in the European Union



The symbol shown here, which is on the product or on its packaging indicates that this product must not be disposed of with other waste. It is the user's responsibility to dispose of their waste equipment by handing it over to a designated collection point for recycling waste electrical equipment and electronic equipment. For more information about where you can drop off your waste equipment for recycling, please contact your local city office, your household waste disposal service or where you purchased the product.



WARNING: cancer and reproductive harm - www.P65Warnings.ca.gov



Evaluation of apparatus based on altitude not exceeding 2000m. There may be some potential safety hazard if the apparatus is operated at altitude exceeding 2000m.



Evaluation of apparatus based on the temperate climate conditions only. There may be some potential safety hazard if the apparatus is operated in tropical climate conditions.

Electromagnetic Compatibility

EN 55032:2015, Class B, EN 55016-2-1:2009 A1 2011, EN 55016-2-3:2010 A1 2010, EN 55035:2017, EN 61000-4-2:2009, EN 61000-4-3:2006 A1 2008 A2 2010, EN 61000-4-4:2012, EN 61000-4-5:2014 A1 2017, EN 61000-4-6:2014, EN 6100-4-11:2004 A1 2017, EN 61000-3-2:2014, EN 61000-3-2:2013, FCC Part 15B Class B, ANSI C63.4:2014, ICES-003 Issue 6: Class B

Audio input and output ports are screened cable ports and any connections to them should be made using braid-screened cable and metal conductor shells in order to provide a low impedance connection between the cable screen and the equipment.

WARNING: Operation of this equipment in a residential environment could cause radio interference.

Environmental

- Operating Temperature: +1 to 30 degrees Celsius.
- Storage: -20 to 50 degrees Celsius.

For more information and guidance, please read your devices' User Manual or visit the Cranborne Audio website:

www.cranborne-audio.com